

PLFY-P-VCM-E
PLFY-P-VBM-E

1. SPECIFICATIONS	1 - 78
2. EXTERNAL DIMENSIONS	1 - 81
3. CENTER OF GRAVITY	1 - 83
4. ELECTRICAL WIRING DIAGRAMS	1 - 84
5. SOUND LEVELS	
5-1. Sound levels	1 - 86
5-2. NC curves	1 - 86
6. TEMPERATURE/AIRFLOW DISTRIBUTIONS	
6-1. Temperature distributions	1 - 88
6-2. Airflow distributions	1 - 90
7. Optional parts for PLFY-P-VBM-E	1 - 91

1. SPECIFICATIONS

R410A Data G6

Model			PLFY-P20VCM-E	PLFY-P25VCM-E	PLFY-P32VCM-E	PLFY-P40VCM-E	
Power source			1-phase 220-240V 50Hz				
Cooling capacity (Nominal)	*1	kW	2.2	2.8	3.6	4.5	
		kcal / h	1,900	2,400	3,100	3,900	
	*1	Btu / h	7,500	9,600	12,300	15,400	
		kcal / h	2,000	2,500	3,150	4,000	
	*4	Power input	kW	0.05	0.05	0.06	0.06
	*4	Current input	A	0.23	0.23	0.28	0.28
Heating capacity (Nominal)	*3	kW	2.5	3.2	4.0	5.0	
		kcal / h	2,200	2,800	3,400	4,300	
	*3	Btu / h	8,500	10,900	13,600	17,100	
		kW	0.05	0.05	0.06	0.06	
	*4	Power input	kW	0.05	0.05	0.06	0.06
	*4	Current input	A	0.23	0.23	0.28	0.28
External finish			Galvanized steel sheet, with grey heat insulation				
External dimension H x W x D		mm	208 x 570 x 570	208 x 570 x 570	208 x 570 x 570	208 x 570 x 570	
		in.	8-1/4 x 22-1/2 x 22-1/2	8-1/4 x 22-1/2 x 22-1/2	8-1/4 x 22-1/2 x 22-1/2	8-1/4 x 22-1/2 x 22-1/2	
Net weight		kg (lb)	15.5 (35)	15.5 (35)	17 (38)	17 (38)	
Decoration panel	Model		SLP-2AA	SLP-2AA	SLP-2AA	SLP-2AA	
	External finish		White Munsell(0.7Y 8.59/0.97)				
	Dimension	mm	20 x 650 x 650	20 x 650 x 650	20 x 650 x 650	20 x 650 x 650	
		in.	13/16 x 25-5/8 x 25-5/8	13/16 x 25-5/8 x 25-5/8	13/16 x 25-5/8 x 25-5/8	13/16 x 25-5/8 x 25-5/8	
	Net Weight		kg (lb)	3 (7)	3 (7)	3 (7)	
	Cord heater		kW	0.015	0.015	0.015	0.015
Heat exchanger			Cross fin & copper tube				
FAN	Type x Quantity		Turbo fan x 1				
	External static press.		0Pa (0mmH ₂ O)	0Pa (0mmH ₂ O)	0Pa (0mmH ₂ O)	0Pa (0mmH ₂ O)	
	Motor type		Single phase induction motor				
	Motor output	kW	0.011	0.015	0.02	0.02	
	Driving mechanism		Direct-driven by motor				
	Airflow rate	m ³ / min	8-9-10	8-9-10	8-9-11	8-9-11	
L / s		133-150-167	133-150-167	133-150-183	133-150-183		
cfm		283-318-353	283-318-353	283-318-388	283-318-388		
Sound pressure level (Low-Mid-High) (measured in anechoic room) *4		dB <A>	28-31-35 (230V)	28-31-37 (230V)	29-33-38 (230V)	30-34-39 (230V)	
Insulation material			Polyethylene foam (softlon FR)				
Air filter			PP honeycomb fabric (long life type)				
Protection device			Fuse				
Refrigerant control device			LEV				
Connectable outdoor unit			R410A, R407C, R22 CITY MULTI				
Diameter of refrigerant pipe	Liquid	mm (in.)	ø6.35 (ø1/4) Flare	ø6.35 (ø1/4) Flare	ø6.35 (ø1/4) Flare	ø6.35 (ø1/4) Flare	
	Gas	mm (in.)	ø12.7 (ø1/2) Flare	ø12.7 (ø1/2) Flare	ø12.7 (ø1/2) Flare	ø12.7 (ø1/2) Flare	
Field drain pipe size		mm (in.)	O.D. 32 (1-1/4)				
Drawing	External		IU-VRG01N654				
	Wiring		IU-VRG79N625				
	Refrigerant circle		-				
Standard attachment	Document		Installation manual, Instruction book				
	Accessory		Drain hose I.D. 32mm (1-1/4) (flexible joint)				
Remark	Optional parts		Decoration panel : SLP-2AA *PLFY-P-VCM-E should use together with SLP-2AA.				
	Installation		Details on foundation work, duct work, insulation work, electrical wiring, power source switch, and other items shall be referred to the Installation Manual.				
Note :	*1 Nominal cooling condition		*2 Nominal cooling condition		*3 Nominal heating condition		
	Indoor : 27°CDB/19°CWB (81°FDB/66°FWB) Outdoor : 35°CDB (95°FDB) Pipe length : 7.5 m (24-9/16 ft) Level difference : 0 m (0 ft)		27°CDB/19.5°CWB (81°FDB/67°FWB) 35°CDB (95°FDB) 5 m (16-3/8 ft) 0 m (0 ft)		20°CDB (68°FDB) 7°CDB/6°CWB (45°FDB/43°FWB) 7.5 m (24-9/16 ft) 0 m (0 ft)		
* Nominal conditions *1, *3 are subject to JIS B8615-1. * Due to continuing improvement, above specification may be subject to change without notice. *4 The values are measured at the rated external static pressure.						Unit converter kcal = kW x 860 Btu/h = kW x 3,412 cfm = m ³ /min x 35.31 lb = kg / 0.4536	

Ref.: Spec_PLFY-P-VCM-E

1. SPECIFICATIONS

R410A Data G6

Model		PLFY-P32VBM-E	PLFY-P40VBM-E	PLFY-P50VBM-E	PLFY-P63VBM-E	
Power source		1-phase 220-240V 50Hz, 1-phase 220V 60Hz				
Cooling capacity (Nominal)	* 1 kW	3.6	4.5	5.6	7.1	
	* 1 kcal / h	3,100	3,900	4,800	6,100	
	* 1 Btu / h	12,300	15,400	19,100	24,200	
	* 2 kcal / h	3,150	4,000	5,000	6,300	
	*4 Power input kW	0.03	0.04	0.04	0.05	
*4 Current input A	0.22	0.29	0.29	0.36		
Heating capacity (Nominal)	* 3 kW	4.0	5.0	6.3	8.0	
	* 3 kcal / h	3,400	4,300	5,400	6,900	
	* 3 Btu / h	13,600	17,100	21,500	27,300	
	*4 Power input kW	0.02	0.03	0.03	0.04	
	*4 Current input A	0.14	0.22	0.22	0.29	
External finish		Galvanized steel sheet				
External dimension H x W x D		258 x 840 x 840				
		10-3/16 x 33-1/8 x 33-1/8				
Net weight		22 (49)	22 (49)	22 (49)	23 (51)	
Decoration panel	Model	PLP-6BA	PLP-6BA	PLP-6BA	PLP-6BA	
	External finish	MUNSELL (6.4Y 8.9/0.4)				
	Dimension	35 x 950 x 950				
	H x W x D	1-3/8 x 37-7/16 x 37-7/16				
	Net weight	6 (13)				
Heat exchanger		Cross fin (Aluminum fin and copper tube)				
FAN	Type x Quantity	Turbo fan x 1	Turbo fan x 1	Turbo fan x 1	Turbo fan x 1	
	External static press.	Pa	0	0	0	0
		mmH ₂ O	0	0	0	0
	Motor type		DC motor			
	Motor output	kW	0.050	0.050	0.050	0.050
	Driving mechanism		Direct-drive			
	Airflow rate (Low-Mid2- Mid1-High)	m ³ / min	11 - 12 - 13 - 14	12 - 13 - 14 - 16	12 - 13 - 14 - 16	14 - 15 - 16 - 18
L / s		183 - 200 - 217 - 233	200 - 217 - 233 - 267	200 - 217 - 233 - 267	233 - 250 - 267 - 300	
cfm		388 - 424 - 459 - 494	424 - 459 - 494 - 565	424 - 459 - 494 - 565	494 - 530 - 565 - 636	
Sound pressure level (Low-Mid2-Mid1-High) (measured in anechoic room) *4		dB <A>	27 - 28 - 29 - 31	27 - 28 - 30 - 31	27 - 28 - 30 - 31	28 - 29 - 30 - 32
Insulation material		PS				
Air filter		PP honeycomb				
Protection device		Fuse				
Refrigerant control device		LEV				
Connectable outdoor unit		R410A, R407C, R22 CITY MULTI				
Diameter of refrigerant pipe	Liquid (R410A) (R22, R407C)	mm (in.)	φ6.35 (φ1/4) Flare	φ6.35 (φ1/4) Flare	φ6.35 (φ1/4) Flare	φ9.52 (φ3/8) Flare
			φ6.35 (φ1/4) Flare	φ6.35 (φ1/4) Flare	φ9.52 (φ3/8) Flare	φ9.52 (φ3/8) Flare
	Gas (R410A) (R22, R407C)	mm (in.)	φ12.7 (φ1/2) Flare	φ12.7 (φ1/2) Flare	φ12.7 (φ1/2) Flare	φ15.88 (φ5/8) Flare
Field drain pipe size		mm (in.)	O.D. 32 (1-1/4)			
Standard attachment	Document Accessory	Installation Manual, Instruction Book				
Remark	Optional parts					
	Decoration panel **1	PLP-6BA	PLP-6BA	PLP-6BA	PLP-6BA	
	Air outlet shutter plate	PAC-SH51SP-E	PAC-SH51SP-E	PAC-SH51SP-E	PAC-SH51SP-E	
	High efficiency filter element **2	PAC-SH59KF-E	PAC-SH59KF-E	PAC-SH59KF-E	PAC-SH59KF-E	
	Multi-function casement	PAC-SH53TM-E	PAC-SH53TM-E	PAC-SH53TM-E	PAC-SH53TM-E	
Installation		Details on foundation work, duct work, insulation work, electrical wiring, power source switch, and other items shall be referred to the Installation Manual.				
Note :		* 1 Nominal cooling conditions	* 2 Nominal cooling conditions	* 3 Nominal heating conditions	Unit converter	
		Indoor : 27°C DB/19°C WB (81°FDB/66°FWB) Outdoor : 35°C DB (95°FDB) Pipe length : 7.5 m (24-9/16 ft) Level difference : 0 m (0 ft)	27°C DB/19.5°C WB (81°FDB/67°FWB) 35°C DB (95°FDB) 5 m (16-3/8 ft) 0 m (0 ft)	20°C DB (68°FDB) 7°C DB/6°C WB (45°FDB/43°FWB) 7.5 m (24-9/16 ft) 0 m (0 ft)	kcal/h = kW x 860 Btu/h = kW x 3,412 cfm = m ³ /min x 35.31 lb = kg / 0.4536	
		* Nominal conditions 1, 3 are subject to JIS B8615-1. * Due to continuing improvement, above specification may be subject to change without notice. *4 The values are measured at the rated external static pressure.			*Above specification data is subject to rounding variation.	

PLFY-
VCMVBM

1. SPECIFICATIONS

Model		PLFY-P80VBM-E	PLFY-P100VBM-E	PLFY-P125VBM-E		
Power source		1-phase 220-240V 50Hz, 1-phase 220V 60Hz				
Cooling capacity (Nominal)	* 1 kW	9.0	11.2	14.0		
	* 1 kcal / h	7,700	9,600	12,000		
	* 1 Btu / h	30,700	38,200	47,800		
	* 2 kcal / h	8,000	10,000	12,500		
	* 4 Power input kW	0.07	0.15	0.16		
* 4 Current input A	0.51	1.00	1.07			
Heating capacity (Nominal)	* 3 kW	10.0	12.5	16.0		
	* 3 kcal / h	8,600	10,800	13,800		
	* 3 Btu / h	34,100	42,700	54,600		
	* 4 Power input kW	0.06	0.14	0.15		
	* 4 Current input A	0.43	0.94	1.00		
External finish		Galvanized steel sheet				
External dimension H x W x D		258 x 840 x 840 10-3/16 x 33-1/8 x 33-1/8	298 x 840 x 840 11-3/4 x 33-1/8 x 33-1/8			
Net weight		23(51)	27(60)	27(60)		
Decoration panel	Model	PLP-6BA	PLP-6BA	PLP-6BA		
	External finish	MUNSELL (6.4Y 8.9/0.4)				
	Dimension	35 x 950 x 950				
	H x W x D	1-3/8 x 37-7/16 x 37-7/16				
	Net weight	6(13)				
Heat exchanger		Cross fin (Aluminum fin and copper tube)				
FAN	Type x Quantity	Turbo fan x 1	Turbo fan x 1	Turbo fan x 1		
	External static press.	Pa	0	0	0	
		mmH ₂ O	0	0	0	
	Motor type		DC motor			
	Motor output	kW	0.050	0.120	0.120	
	Driving mechanism		Direct-drive			
	Airflow rate (Low-Mid2-Mid1-High)	m ³ / min	16 - 18 - 20 - 22	21 - 24 - 27 - 29	22 - 25 - 28 - 30	
L / s		267 - 300 - 333 - 367	350 - 400 - 450 - 483	367 - 417 - 467 - 500		
	cfm	565 - 636 - 706 - 777	742 - 848 - 953 - 1024	777 - 883 - 989 - 1059		
Sound pressure level (Low-Mid2-Mid1-High) (measured in anechoic room) *4	dB <A>	30 - 32 - 35 - 37	34 - 37 - 39 - 41	35 - 38 - 41 - 43		
Insulation material		PS				
Air filter		PP honeycomb				
Protection device		Fuse				
Refrigerant control device		LEV				
Connectable outdoor unit		R410A, R407C, R22 CITY MULTI				
Diameter of refrigerant pipe	Liquid (R410A) (R22, R407C)	mm (in.)	φ9.52 (φ3/8) Flare	φ9.52 (φ3/8) Flare	φ9.52 (φ3/8) Flare	
			φ9.52 (φ3/8) Flare	φ9.52 (φ3/8) Flare	φ9.52 (φ3/8) Flare	
	Gas (R410A) (R22, R407C)	mm (in.)	φ15.88 (φ5/8) Flare	φ15.88 (φ5/8) Flare	φ15.88 (φ5/8) Flare	
			φ15.88 (φ5/8) Flare	φ19.05 (φ3/4) Flare	φ19.05 (φ3/4) Flare	
Field drain pipe size		mm (in.) O.D. 32 (1-1/4)				
Standard attachment	Document Accessory	Installation Manual, Instruction Book				
Remark	Optional parts					
	Decoration panel **1	PLP-6BA	PLP-6BA	PLP-6BA		
	Air outlet shutter plate	PAC-SH51SP-E	PAC-SH51SP-E	PAC-SH51SP-E		
	High efficiency filter element **2	PAC-SH59KF-E	PAC-SH59KF-E	PAC-SH59KF-E		
	Multi-function casement	PAC-SH53TM-E	PAC-SH53TM-E	PAC-SH53TM-E		
Installation		Details on foundation work, duct work, insulation work, electrical wiring, power source switch, and other items shall be referred to the Installation Manual.				
Note :	* 1 Nominal cooling conditions	* 2 Nominal cooling conditions	* 3 Nominal heating conditions	Unit converter		
	Indoor : 27°C DB/19°C WB (81°FDB/66°FWB) Outdoor : 35°C DB (95°FDB) Pipe length : 7.5 m (24-9/16 ft) Level difference : 0 m (0 ft)	27°C DB/19.5°C WB (81°FDB/67°FWB) 35°C DB (95°FDB) 5 m (16-3/8 ft) 0 m (0 ft)	20°C DB (68°FDB) 7°C DB/6°CWB (45°FDB/43°FWB) 7.5 m (24-9/16 ft) 0 m (0 ft)	kcal/h = kW x 860 Btu/h = kW x 3,412 cfm = m ³ /min x 35.31 lb = kg / 0.4536		
* Nominal conditions 1, 3 are subject to JIS B8615-1. * Due to continuing improvement, above specification may be subject to change without notice. *4 The values are measured at the rated external static pressure.					*Above specification data is subject to rounding variation.	

2. EXTERNAL DIMENSIONS

PLFY-P20,25,32,40VCM-E

Draw. : IU-RG01-N654
Unit : mm

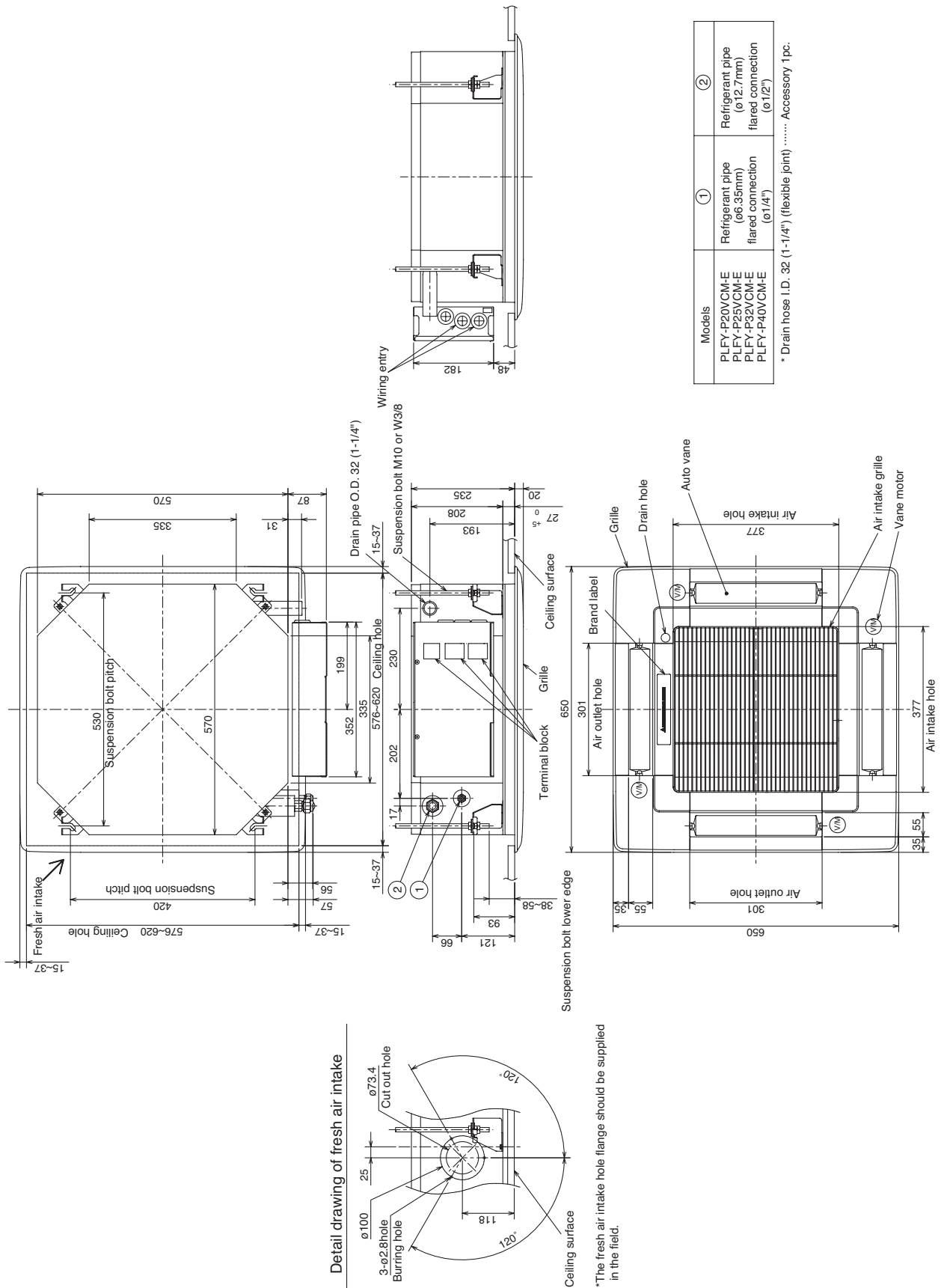

Models	①	②
PLFY-P20VCM-E	Refrigerant pipe (ø6.35mm) flared connection (ø1/4")	Refrigerant pipe (ø12.7mm) flared connection (ø1/2")
PLFY-P25VCM-E		
PLFY-P32VCM-E		
PLFY-P40VCM-E	* Drain hose I.D. 32 (1-1/4") (flexible joint) Accessory 1pc.	

Detail drawing of fresh air intake

*The fresh air intake hole flange should be supplied in the field.

PLFY-VCM/VBM

PLFY-P32,40,50,63,80,100,125VBM-E

Unit : mm

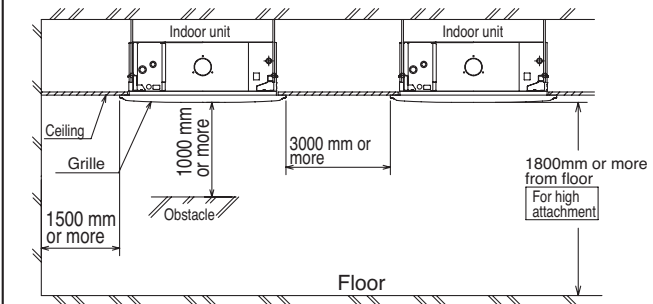
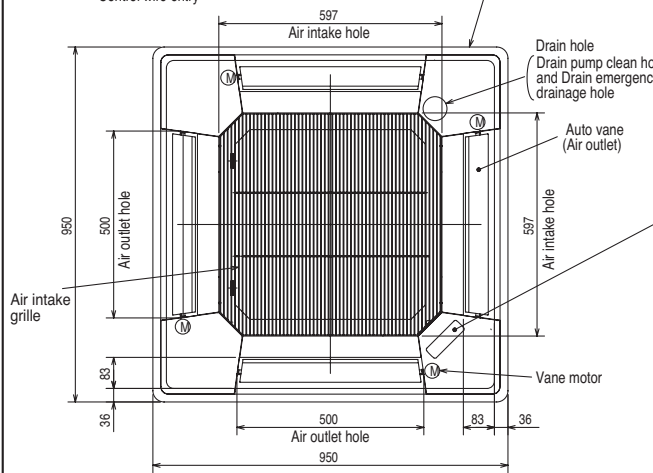
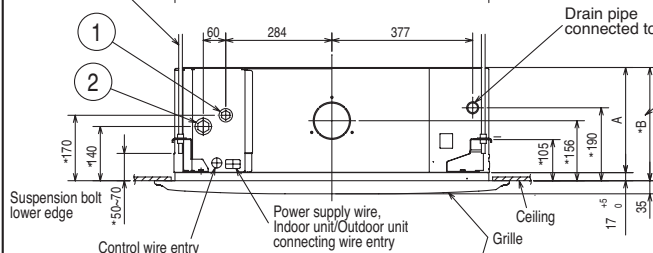
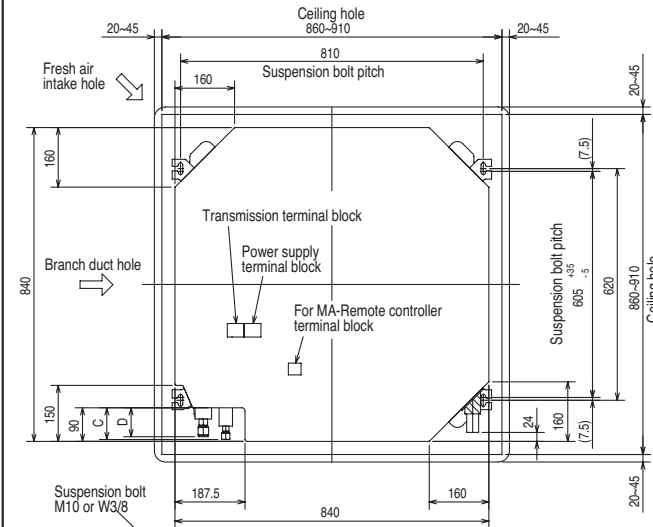

Detail connecting of Branch duct(Both aspects)

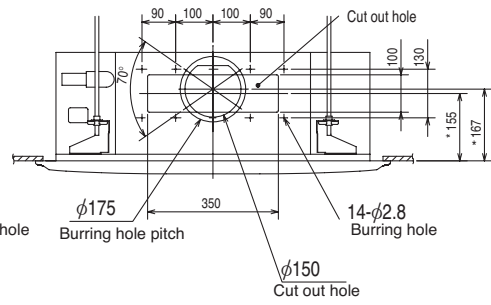

Detail drawing of fresh air intake hole

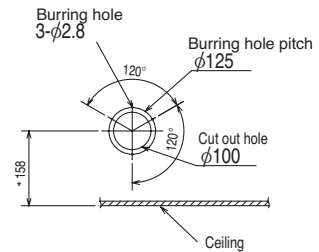

In case of standard grille : PLP-6BA



In case of Auto-Grille : PLP-6BAJ

In case of wireless remote controller : PLP-6BALM

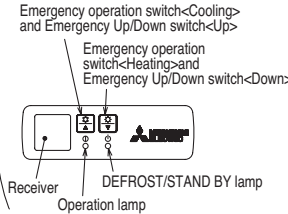

Auto-Grille
Air intake grille Up/down distance

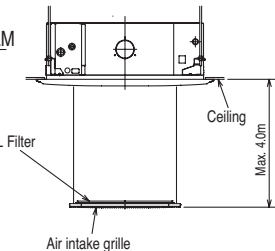

- Note 1. Please choose the Grille from a standard grille, Auto-Grille.
 2. As for drain pipe, please use VP-25(O.D. φ32 PVC TUBE).
 Drain pump inclusion.
 Raise is max 850mm from the ceiling.
 3. As for suspension bolt, please use M10 or W3/8. (Procured at local site)
 4. Electrical box may be removed for the service purpose.
 Make sure to slack the electrical wire little bit for control/power wires connection.
 5. The height of the indoor unit is able to be adjusted with the grille attached.
 6. For the installation of the optional high efficiency filter or optional multi-functional casement.
 1) Requires E or more space between transom and ceiling for the installation.
 2) Add 135 mm to the dimensions * marked on the figure.
 3) The optional high efficiency filter becomes optional multi-functional casement and concomitant use.
 7. When installing the branch ducts, be sure to insulate adequately.
 Otherwise condensation and dripping may occur.
 (It becomes the cause of dew drops/Wear dew.)
 8. As for necessary installation/service space, please refer to the under at figure.
 9. On model P50, P100, P125, use flare nut when connecting the Outdoor unit for R407C, R22.

Accessory ... Drain socket (I.D. 32)

Models	①	②	C	D	B	E	A
PLFY-P32,40VBM-E	Refrigerant pipe---φ 6.35 Flared connection---1/4F	Refrigerant pipe ---φ12.7 Flared connection---1/2F			80	74	
PLFY-P50VBM-E	Refrigerant pipe φ6.35 /φ9.52 Flared connection 1/4F / 3/8F (compatible)	Refrigerant pipe φ12.7 /φ15.88 Flared connection 1/2F / 5/8F (compatible)	241	258	87	78	400
PLFY-P63,80VBM-E	Refrigerant pipe---3/8F Flared connection---φ9.52	Refrigerant pipe---φ15.88 Flared connection---5/8F				77	
PLFY-P100,125VBM-E		Refrigerant pipe φ15.88 / φ19.05 Flared connection 5/8F / 3/4F (compatible)	281	298	85	81	440

PLFY-P20,25,32,40VCM-E

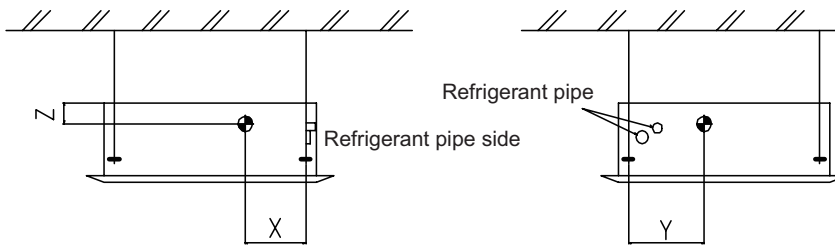

(mm)[in]

Model name	X	Y	Z
PLFY-P20VCM-E	150 [5-29/32]	260 [10-1/4]	105 [4-5/32]
PLFY-P25VCM-E	150 [5-29/32]	260 [10-1/4]	105 [4-5/32]
PLFY-P32VCM-E	150 [5-29/32]	260 [10-1/4]	105 [4-5/32]
PLFY-P40VCM-E	150 [5-29/32]	260 [10-1/4]	105 [4-5/32]

PLFY-P32,40,50,63,80,100,125VBM-E

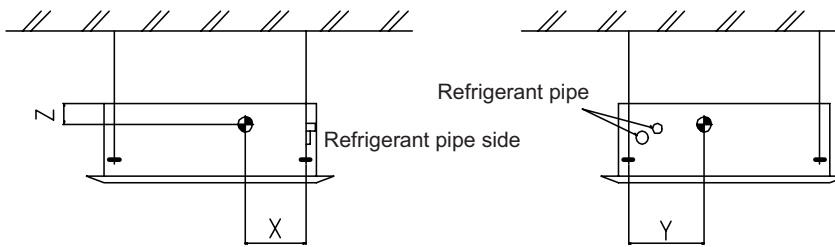

(mm)[in]

Model name	X	Y	Z
PLFY-P32VBM-E	280 [11-1/32]	400 [15-3/4]	105 [4-5/32]
PLFY-P40VBM-E	280 [11-1/32]	400 [15-3/4]	105 [4-5/32]
PLFY-P50VBM-E	280 [11-1/32]	400 [15-3/4]	105 [4-5/32]
PLFY-P63VBM-E	280 [11-1/32]	400 [15-3/4]	105 [4-5/32]
PLFY-P80VBM-E	280 [11-1/32]	400 [15-3/4]	105 [4-5/32]
PLFY-P100VBM-E	280 [11-1/32]	400 [15-3/4]	125 [4-15/16]
PLFY-P125VBM-E	280 [11-1/32]	400 [15-3/4]	125 [4-15/16]

PLFY-VCM/VBM

PLFY-P20,25,32,40VCM-E

Drw. : IU-RG79-N625

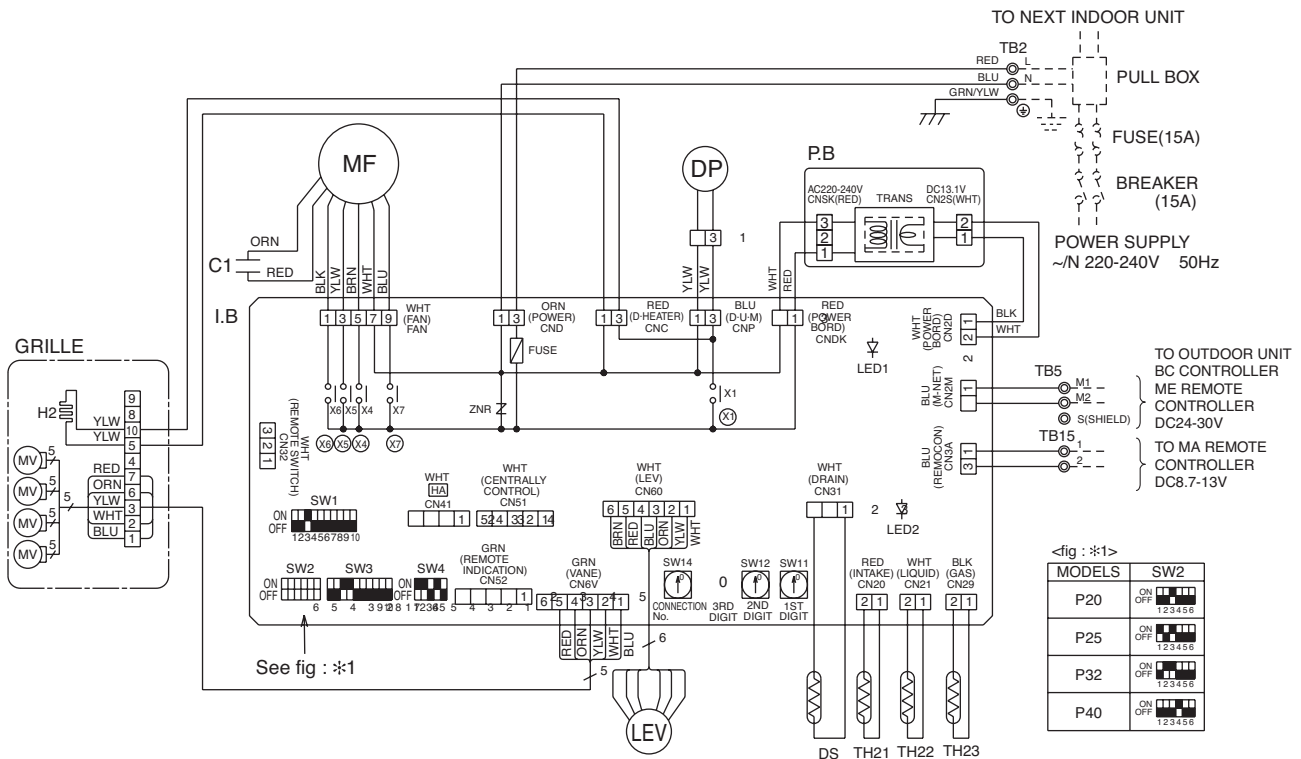

[LEGEND]

SYMBOL	NAME	SYMBOL	NAME
I.B	INDOOR CONTROLLER BOARD	C1	CAPACITOR (FAN MOTOR)
CN32	CONNECTOR	DP	DRAIN WATER LIFTING-UP MACHINE
CN41	CONNECTOR	DS	DRAIN SENSOR
CN51	CONNECTOR	H2	DEW PREVENTION HEATER
CN52	CONNECTOR	LEV	LINEAR EXPANSION VALVE
FUSE	FUSE (6.3A/250V)	MF	FAN MOTOR (WITH THERMAL FUSE)
SW1	SWITCH	MV	VANE MOTOR
SW2	SWITCH	TB2	TERMINAL BLOCK
SW3	SWITCH	TB5	TERMINAL BLOCK
SW4	SWITCH	TB15	TERMINAL BLOCK
SW11	SWITCH	TH21	THERMISTOR
SW12	SWITCH	TH22	THERMISTOR
SW14	SWITCH	TH23	THERMISTOR
X1	AUX. RELAY	P.B	INDOOR POWER BOARD
X4	AUX. RELAY		
X5	AUX. RELAY		
X6	AUX. RELAY		
X7	AUX. RELAY		
ZNR	VARIATOR		

Notes:

1. At servicing for outdoor unit, always follow the wiring diagram of outdoor unit.
2. In case of using MA Remote controller, please connect to TB15. (Remote controller wire is non-polar.)
3. In case of using M-NET, please connect to TB5. (Transmission line is non-polar.)
4. Symbol[S] of TB5 is the shield wire connection.
5. Symbols used in wiring diagram above are, ⊙ : terminal block, □ : connector.
6. The setting of the SW2 dip switches differs in the capacity for the detail, refer to the fig : *1.

LED on indoor board for service

Mark	Meaning	Function
LED1	Main power supply	Main power supply (Indoor unit: 220-240V) power on → lamp is lit
LED2	Power supply for MA Remote controller	Power supply for MA Remote controller on → lamp is lit

PLFY-P32,40,50,63,80,100,125VBM-E

[LEGEND]

SYMBOL	NAME	SYMBOL	NAME	SYMBOL	NAME
I. B	INDOOR CONTROLLER BOARD	TB2	TERMINAL BLOCK	OPTION PART	
CN27	CONNECTOR DAMPER	TB5	TERMINAL BLOCK TRANSMISSION	W.B	PCB FOR WIRELESS REMOTE CONTROLLER
CN32	CONNECTOR REMOTE SWITCH	TB15	TERMINAL BLOCK MA-REMOTE CONTROLLER	BZ	BUZZER
CN51	CENTRALLY CONTROL	TH21	THERMISTOR ROOM TEMP. DETECTION (0°C / 15kΩ, 25°C / 5.4kΩ)	LED1	LED (OPERATION INDICATION : GREEN)
CN52	CONNECTOR REMOTE INDICATION	TH22	THERMISTOR PIPE TEMP. DETECTION / LIQUID (0°C / 15kΩ, 25°C / 5.4kΩ)	LED2	LED (PREPARATION FOR HEATING : ORANGE)
DSA	SURGE ABSORBER	TH23	THERMISTOR PIPE TEMP. DETECTION / GAS (0°C / 15kΩ, 25°C / 5.4kΩ)	RU	RECEIVING UNIT
FUSE	FUSE (T6.3AL250V)	A. B	ADDRESS BOARD	SW1	EMERGENCY OPERATION (HEAT / DOWN)
LED1	POWER SUPPLY (I. B)	SWA	SWITCH CEILING HEIGHT SELECTOR	SW2	EMERGENCY OPERATION (COOL / UP)
LED2	POWER SUPPLY (I. B)	SWB	SWITCH DISCHARGE OUTLET NUMBER SELECTOR		
SW2	SWITCH CAPACITY CODE	SWC	SWITCH OPTION SELECTOR		
SW3	SWITCH MODE SELECTION	SW11	SWITCH ADDRESS SETTING 1ST DIGIT		
SW4	SWITCH MODEL SELECTION	SW12	SWITCH ADDRESS SETTING 2ND DIGIT		
SWE	SWITCH DRAIN-UP MACHINE (TEST MODE)	SW14	SWITCH CONNECTION NO.		
X1	AUX. RELAY DRAIN WATER LIFTING-UP MACH.				
ZNR01,02	VARIATOR				
DP	DRAIN-UP MACHINE				
FS	DRAIN FLOAT SWITCH				
LEV	LINEAR EXPANSION VALVE				
MF	FAN MOTOR				
MV	VANE MOTOR				

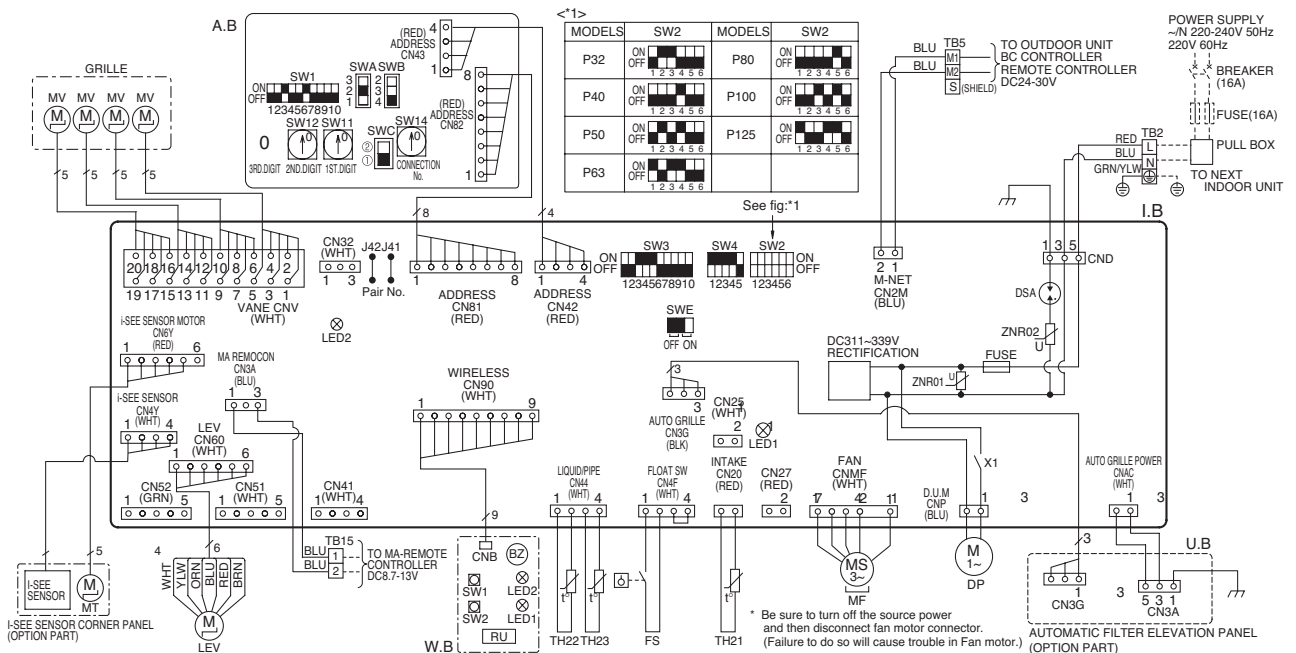

- NOTES:
1. At servicing for outdoor unit, always follow the wiring diagram of outdoor unit.
 2. In case of using MA-Remote controller, please connect to TB15.
(Remote controller wire is non-polar.)
 3. In case of using M-NET, please connect to TB5. (Transmission line is non-polar.)
 4. Symbol [S] of TB5 is the shield wire connection.
 5. Symbols used in wiring diagram above are, □□□: terminal block, ○○○○: connector.
 6. The setting of the SW2 dip switches differs in the capacity. For the detail, refer to fig-<1>.

LED on indoor board for service

Mark	Meaning	Function
LED1	Main power supply	Main Power supply (Indoor unit:220-240V) power on – lamp is lit
LED2	Power supply for MA-Remote controller	Power supply for MA-Remote controller on – lamp is lit

PLFY-VCM/VBM

5-1. Sound levels

PLFY-P-VCM-E, VBM-E

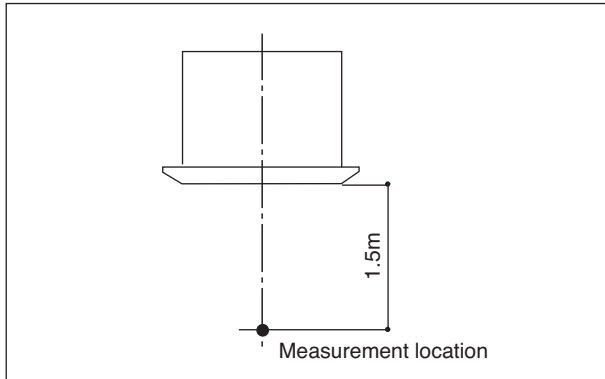

Sound level at anechoic room : Low-Mid-High

	Sound level dB (A)
PLFY-P20VCM-E	28-31-35
PLFY-P25VCM-E	28-31-37
PLFY-P32VCM-E	29-33-38
PLFY-P40VCM-E	30-34-39

Sound level at anechoic room : Low-Mid2-Mid1-High

	Sound level dB (A)
PLFY-P32VBM-E	27-28-29-31
PLFY-P40VBM-E	27-28-30-31
PLFY-P50VBM-E	27-28-30-31
PLFY-P63VBM-E	28-29-30-32
PLFY-P80VBM-E	30-32-35-37
PLFY-P100VBM-E	34-37-39-41
PLFY-P125VBM-E	35-38-41-43

* Measured in anechoic room.

5-2. NC curves

PLFY-P20VCM-E

External static pressure : 0Pa
Power source : 220,230,240V, 50Hz

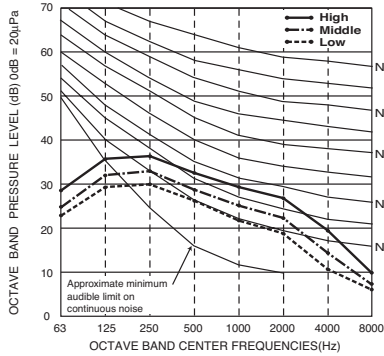

PLFY-P25VCM-E

External static pressure : 0Pa
Power source : 220,230,240V, 50Hz

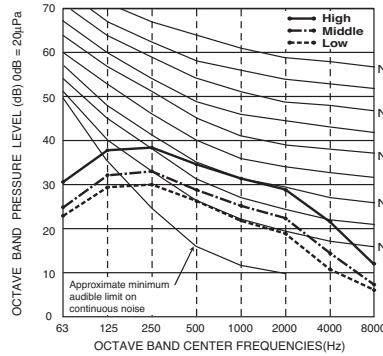

PLFY-P32VCM-E

External static pressure : 0Pa
Power source : 220,230,240V, 50Hz

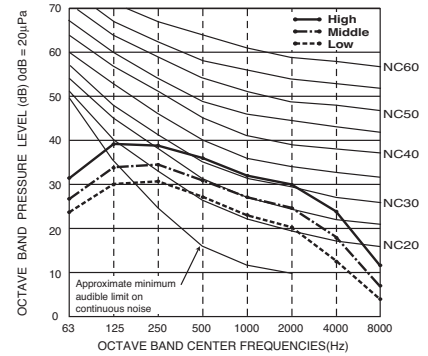

PLFY-P40VCM-E

External static pressure : 0Pa
Power source : 220,230,240V, 50Hz

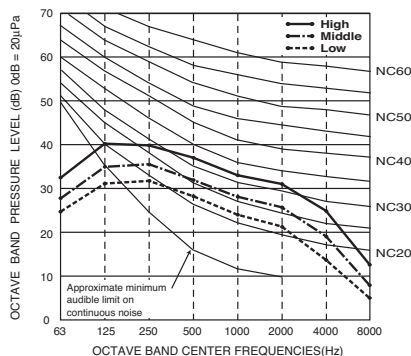

PLFY-VCM/VBM

5-2. NC curves

PLFY-P32VBM-E

External static pressure : 0Pa
Power source : 220,230,240V, 50Hz / 220V, 60Hz

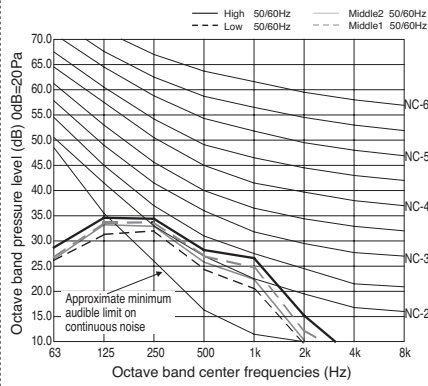

PLFY-P40VBM-E

External static pressure : 0Pa
Power source : 220,230,240V, 50Hz / 220V, 60Hz

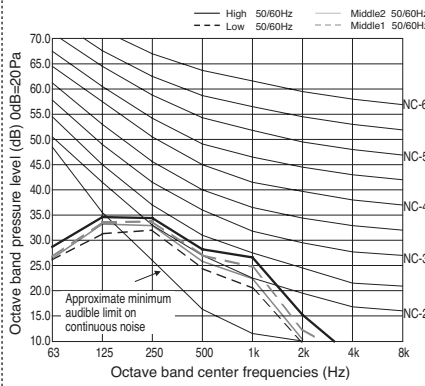

PLFY-P50VBM-E

External static pressure : 0Pa
Power source : 220,230,240V, 50Hz / 220V, 60Hz

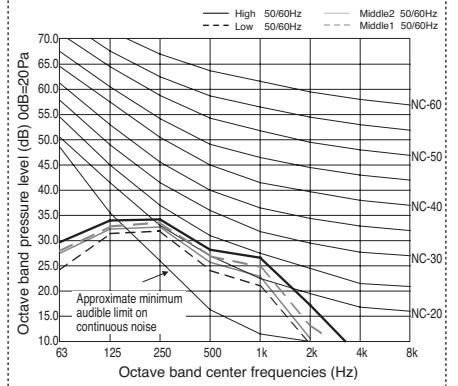

PLFY-P63VBM-E

External static pressure : 0Pa
Power source : 220,230,240V, 50Hz / 220V, 60Hz

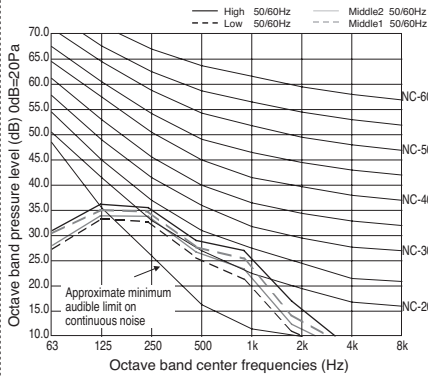

PLFY-P80VBM-E

External static pressure : 0Pa
Power source : 220,230,240V, 50Hz / 220V, 60Hz

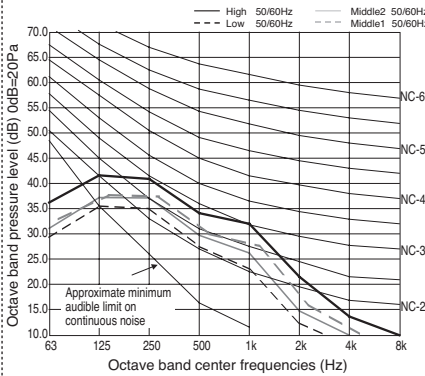

PLFY-P100VBM-E

External static pressure : 0Pa
Power source : 220,230,240V, 50Hz / 220V, 60Hz

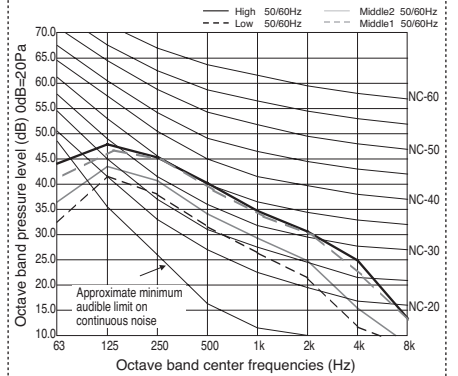

PLFY-P125VBM-E

External static pressure : 0Pa
Power source : 220,230,240V, 50Hz / 220V, 60Hz

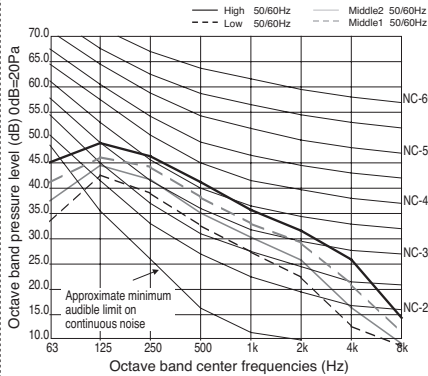

PLFY-
VCMVBM

6-1. Temperature distributions

PLFY-P-VCM-E

<Cooling mode>

Flow angle 30°

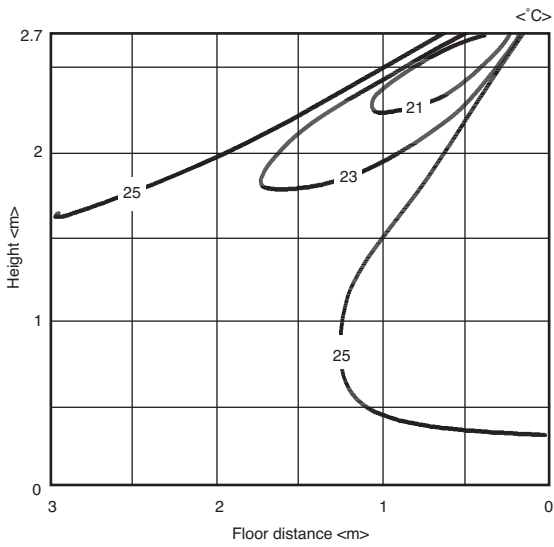

<Heating mode>

Flow angle 70°

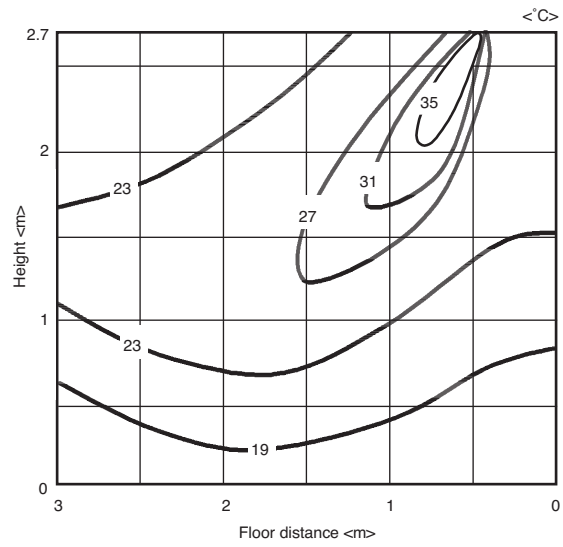

Note : These figures show typical temperature distributions in the conditions above. In the actual installation, they may differ from these figures under the influence of air temperature conditions, ceiling height, cooling/heating load, obstacles, etc.

PLFY-
VCM/VBM

6-1. Temperature distributions

PLFY-P-VBM-E

• PLY-P80VBM-E
 <Cooling mode> Standard
 Flow angle : 30° 4-way flow
 ceiling height : 2.7 m

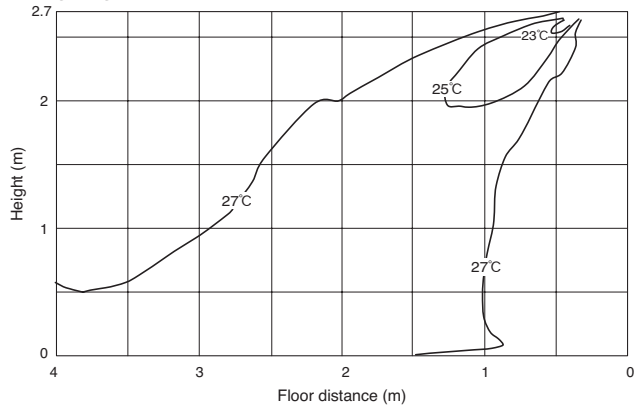

• PLY-P80VBM-E
 <Heating mode> Standard
 Flow angle : 60° 4-way flow
 ceiling height : 2.7 m

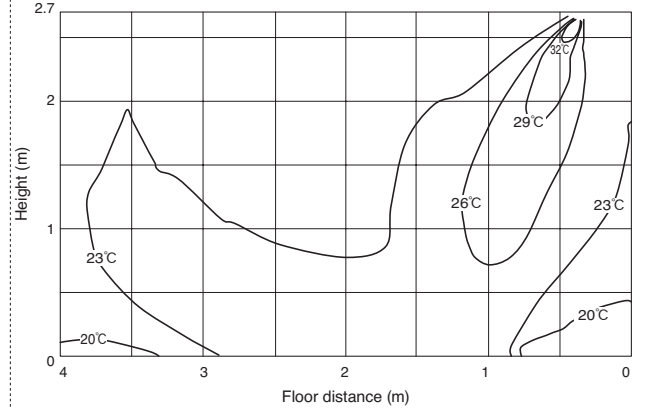

• PLY-P125VBM-E
 <Cooling mode> Standard
 Flow angle : 30° 4-way flow
 ceiling height : 3.2 m

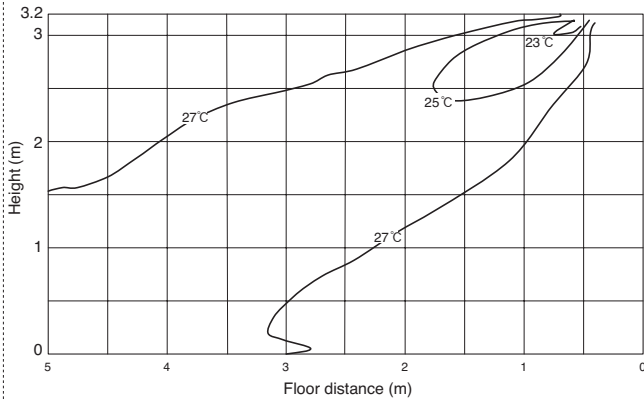

• PLY-P125VBM-E
 <Heating mode> Standard
 Flow angle : 60° 4-way flow
 ceiling height : 3.2 m

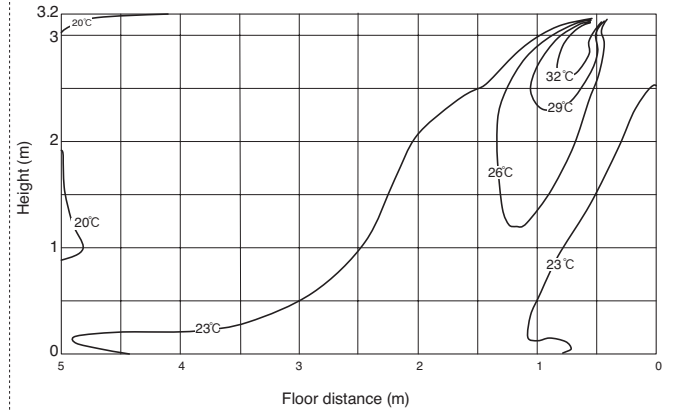

Note : These figures show typical temperature distributions in the conditions above. In the actual installation, they may differ from these figures under the influence of air temperature conditions, ceiling height, cooling/heating load, obstacles, etc.

PLFY-
VCMVBM

6-2. Airflow distributions

PLFY-P-VCM-E

<Fan mode>
Flow angle 70°

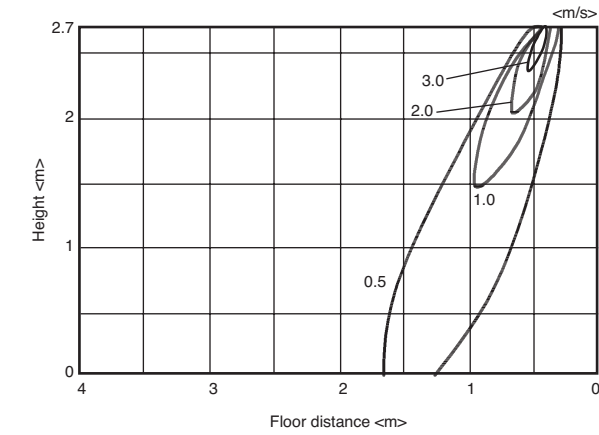

<Fan mode>
Flow angle 30°

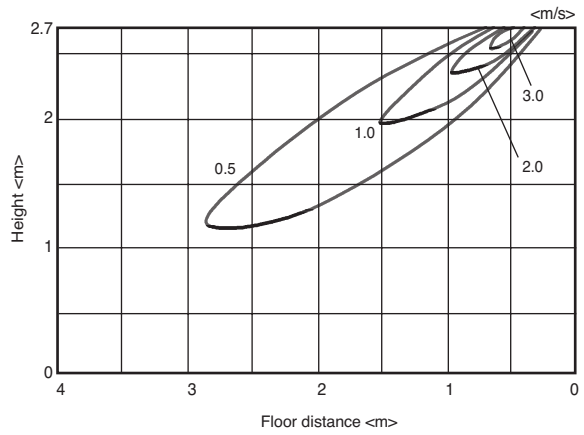

PLFY-P80VBM-E

<Heating mode>
Flow angle 60°

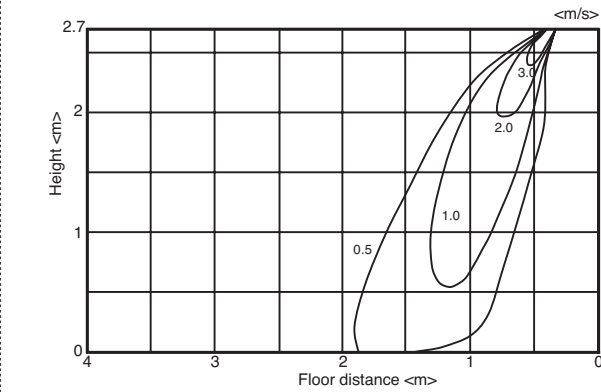

<Cooling mode>
Flow angle 30°

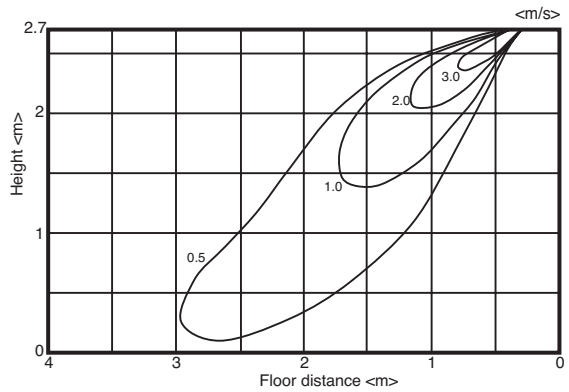

PLFY-P125VBM-E

<Heating mode>
Flow angle 60°

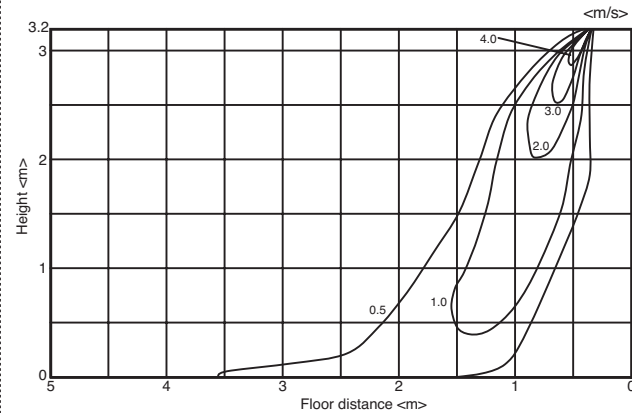

<Cooling mode>
Flow angle 30°

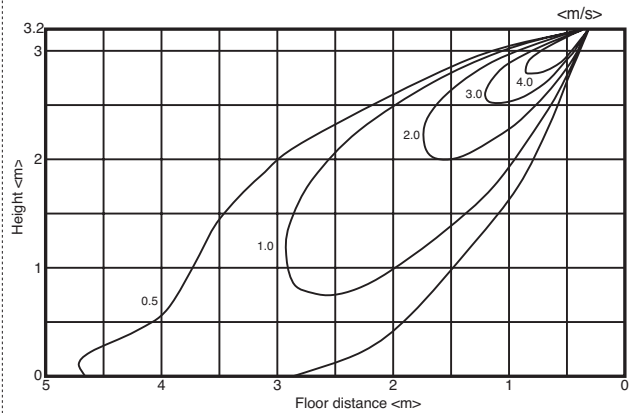

Note : These figures show typical airflow distributions in the conditions above. In the actual installation, they may differ from these figures under the influence of air temperature conditions, ceiling height, cooling/heating load, obstacles, etc.

Optional parts line up for the Indoor unit

	Description	Model
PLFY-P-VBM-E	Air outlet shutter plate	PAC-SH51SP-E
	Multi-function casement	PAC-SH53TM-E
	High efficiency filter element	PAC-SH59KF-E
	i-see Sensor corner panel	PAC-SA1ME-E
	Automatic filter elevation panel	PLP-6BAJ
	Wireless signal receiver	PAR-SA9FA-E
	Space panel	PAC-SH48AS-E
	Duct flange for fresh air intake	PAC-SH65OF-E

PLFY-P-VBM-E

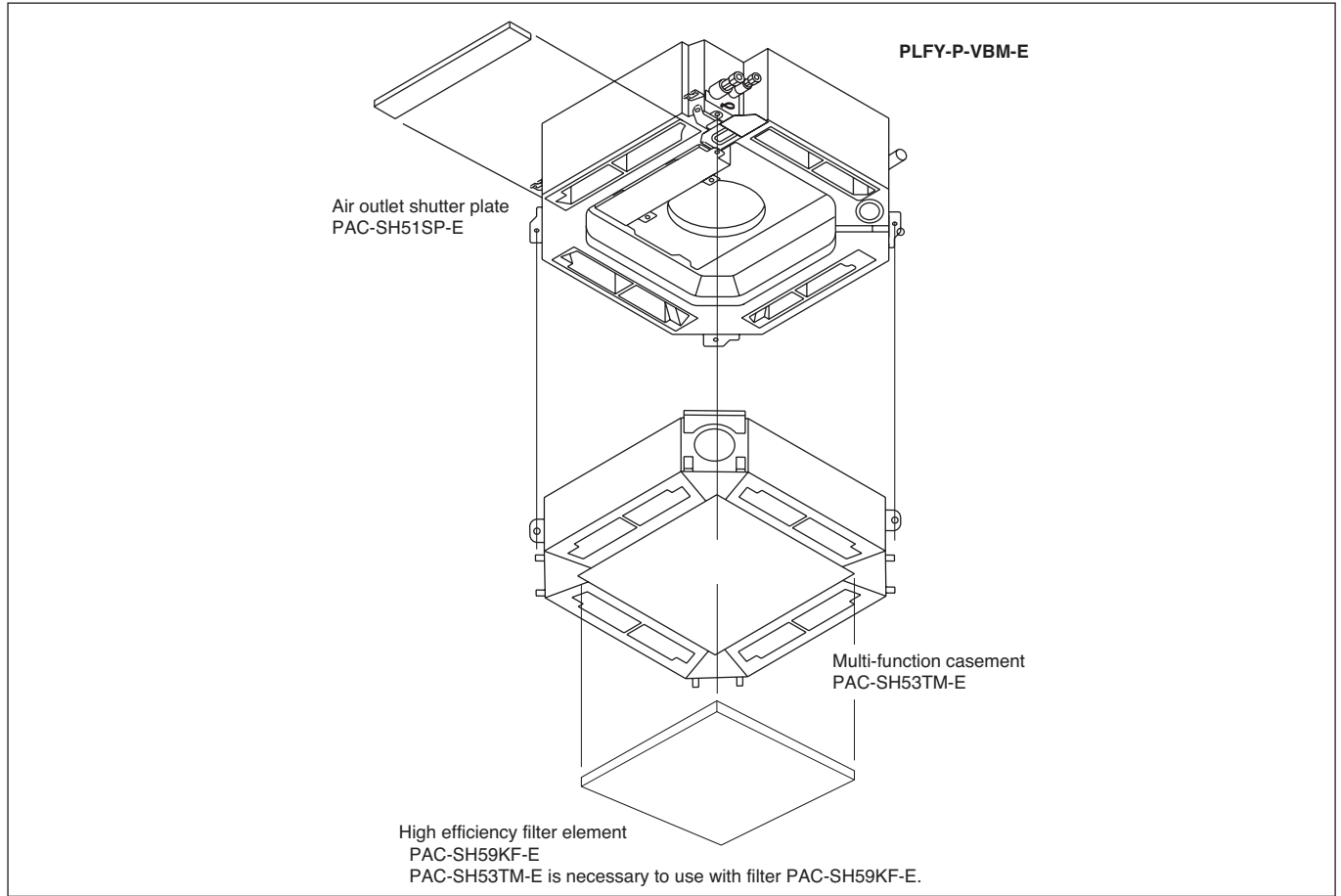

Air outlet shutter plate PAC-SH51SP-E

Using the air outlet shutter plate to block the air outlet to modify the air-way from 4 to 3 or 2.
 With 1 PAC-SH51SP-E, 4 air-ways can be changed to 3;
 With 2 PAC-SH51SP-E, 4 air-ways can be changed to 2;
 Changing to 1 way is not allowed.
 Material: Foamed polyethylene + foamed urethane, color: black.

Item	① Shutter plate	② Insulator	
Quantity	2	1	
Shape			

Detailed installation information should be referred to its Installation Manual (BH79G726H01)

High efficiency filter element PAC-SH59KF-E

Life span: 2,500 hr (Dust concentration 0.15mg/m³); Colorimetric method 65% (JIS 11 class)); No re-production.
 * The actual dust situation affects the filter life span, which should be considered at the applying site.
 Material: Electrostatic polyolefin fiber
 High efficiency filter element PAC-SH59KF-E should be used together with the Multi-function casement PAC-SH53TM-E. When using PAC-SH59KF-E, switching on SWC of the Indoor unit address board is needed. Details are referred to its Installation Manual.

Quantity	1	
Shape		

Detailed installation information should be referred to its Installation Manual (BH79G727H01)

PLFY-VCMM/BM

■ Multi-function casement PAC-SH53TM-E

Multi-function casement is used for High efficiency filter element and/or fresh air intake from outdoor. It should be used with High efficiency filter element PAC-SH59KF-E (Colorimetric method 65%). Fresh air intake on the Multi-function casement is possible from any 2 or less corners among the 4 ones. But duct and flange on the casement should be prepare locally.

Item	① Multi-functional casement	② Screw with washer (black)	③ Screw
Quantity	1	4	8
Shape		M5X0.8X25 	M5X0.8X12
Item	④ Decorative panel securing bracket	⑤ Insulator A for Decorative panel	⑥ Insulator B for Decorative panel
Quantity	4	1	1
Shape	With insulator 		

Detailed installation information should be referred to its Installation Manual (RG79Y264H01)

■ i-see sensor corner panel PAC-SA1ME-E

i-see sensor provides comfortable space as it detects the floor temperature to prevent spotty temperature. And that enables the unit to save energy.

Attention

Make sure that there are no gaps between the unit and the grille, and the grille and ceiling.

* It way cause dew dripping.

Item	① i-see sensor corner panel	② Plastic fastener
Quantity	1	2
Shape		

Detailed installation information should be referred to its Installation Manual (RG79V563H01)

■ Automatic filter elevation panel PLP-6BAJ

- Air intake grille can be lifted and lowered automatically by wired remote controller (MA type : PAR-21MAA) or wireless remote controller (Item ⑨).
- Lowering the air intake grille allows you to clean the filter easily.
- You can set up eight different stages of lowering distance for the air intake grille according to the set up location if desired. (Maximum : 4m)

Item	① Decorative panel	② Screw with washer	③ Installation gauge	④ Plastic fastener
Quantity	1	4	1	3
Shape	Vane 	M5 × 0.8 × 25 	 (Used split into four pieces)	
Item	⑤ Tag	⑥ Screw	⑦ Screw	⑧ Screw
Quantity	1	4	1	3
Shape		4 × 8 Only three are used 	4 × 12 	M5 × 10
Item	⑨ Wireless remote controller			
Quantity	1			
Shape				

Detailed installation information should be referred to its Installation Manual (RG79D167K01)

PLFY-VBM/VBM

■ Wireless signal receiver PAR-SA9FA-E

Wireless signal receiver PAR-SA9FA-E is necessary for using wireless remote controller. PAR-SA9FA-E is a corner panel with the signal receiver for wireless remote controller.

Item	① Wireless signal receiver	
Quantity	1	
Shape		

Detailed installation information should be referred to its Installation Manual (RG79V531H01)

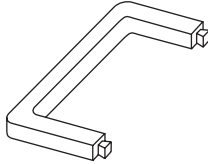
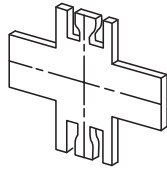

■ Space panel PAC-SH48AS-E

Decorative cover for the installation when the ceiling height is low.

Item	① Space panel	② Gauge for installation
Quantity	2	1
Shape		

■ Duct flange for fresh air intake PAC-SH65OF-E

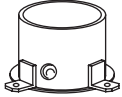
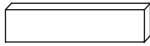
Part to attach a duct to take in fresh air from outdoors.

Item	① Duct flange	② Insulator	③ Screws (M4 x 10)
Quantity	1	1	3
Shape			

PLFY-
VCM/VBM

PLFY-
VCM/VBM